

## Torx® Sockets

### How to use

### Bit Holder, 8mm Drive Torx® Bits & MSH

This is the solution for the breakage of bigger size of torx sockets. In order to escape the risk of damage by the higher fastening torque, we recommend the combination of 8mm drive bits and this specialized bit holder. MSH holder is applicable.

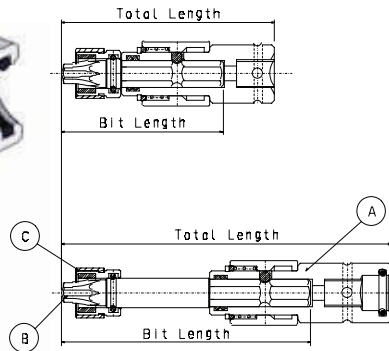
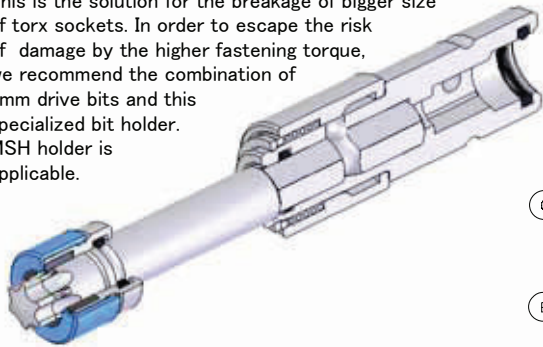

#### «Bit Holder/Normal type»

| Bit Length (mm) | Total Length (mm) |         |
|-----------------|-------------------|---------|
|                 | DC-38S            | DC-48S  |
| 55 →            | (72.5)            | (75.5)  |
| 85 →            | (102.5)           | (105.5) |

#### «Bit Holder/AV type»

| Bit Length (mm) | Total Length (mm) |          |
|-----------------|-------------------|----------|
|                 | AVDC-38S          | AVDC-48S |
| 55 →            | (82.5)            | (85.5)   |
| 85 →            | (112.5)           | (115.5)  |

### ① Bit Holder

● for HEX8.00mm Drive Bits

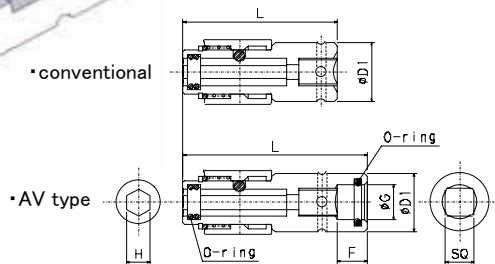
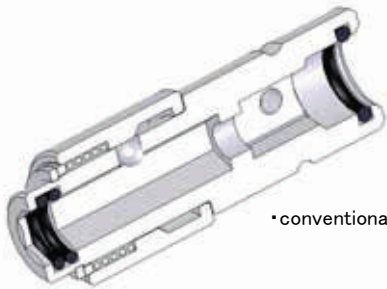

9.52mm (3/8")  
12.7mm (1/2")

#### 【 Spec. 】

| Part No. | SQ (mm) | H (mm) | φD (mm) | φG (mm) | F (mm) | L (mm) |
|----------|---------|--------|---------|---------|--------|--------|
| DC-38S   | 9.52    | 8      | 20      | -       | -      | 52     |
| DC-48S   | 12.7    | 8      | 25      | -       | -      | 55     |
| AVDC-38S | 9.52    | 8      | 20      | 12      | 10     | 62     |
| AVDC-48S | 12.7    | 8      | 25      | 16      | 10     | 65     |

«Applicable Bits»

**8mm Drive**

### ② Torx® Bits 【 HEX8.00mm Drive 】

● GR type (groove designed Bits)

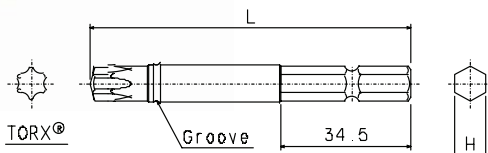

**8mm Drive**

8.00mm (5/16")

#### 【 Spec. 】

| Part No.   | Driver Size | (mm) Ref. | H (mm) | L (mm) |
|------------|-------------|-----------|--------|--------|
| 8GR-T40X55 | T40         | 6.60      | 8      | 55     |
| 8GR-T40X85 | T40         | 6.60      | 8      | 85     |
| 8GR-T45X55 | T45         | 7.77      | 8      | 55     |
| 8GR-T45X85 | T45         | 7.77      | 8      | 85     |
| 8GR-T50X55 | T50         | 8.79      | 8      | 55     |
| 8GR-T50X85 | T50         | 8.79      | 8      | 85     |
| 8GR-T55X55 | T55         | 11.2      | 8      | 55     |
| 8GR-T55X85 | T55         | 11.2      | 8      | 85     |

### ③ MSH (Magnetic Screw Holder)

● for Torx® 8mm Drive Bits — GR type —



#### 【 Standard Spec. 】

We offer the specials on your request.

| Part No. | Applicable Bits<br>Torx® Bits |
|----------|-------------------------------|
| MSHT45-8 | 8GR-T40, T45, T50             |
| MSHT56-8 | 8GR-T55                       |